



## YueQing Yulin Electronic Co., Ltd

Adds:F/6 No.19 Ke'aisi Road, Xiangyang industrial Zone,Liushi Town,YueQing City, Zhejiang Province, China 325600

Website: www.indicatorlight.com

Tel: 0577-62768130

Fax: 0577-62768130

# METAL ROCKER SWITCH SPECIFICATION FOR APPROVAL

## 规 格 说 明 书

CUSTOMER'S CODE: \_\_\_\_\_

DESCRIPTION: 3PDT SWITCH

SPECIFICATION: \_\_\_\_\_

DATE : 2020-01-13

PART NO.: \_\_\_\_\_

REFERENCE No.:

Approved By Customer 编 制	Qualified By 审 核	Form Designer 批 准



# YueQing Yulin Electronic Co., Ltd

Adds:F/6 No.19 Ke'aisi Road, Xiangyang industrial Zone,Liushi Town,YueQing City, Zhejiang Province, China 325600

Website: [www.indicatorlight.com](http://www.indicatorlight.com)

Tel: 0577-62768130

Fax: 0577-62768130

## 1. Picture:



## 2. Drawing:

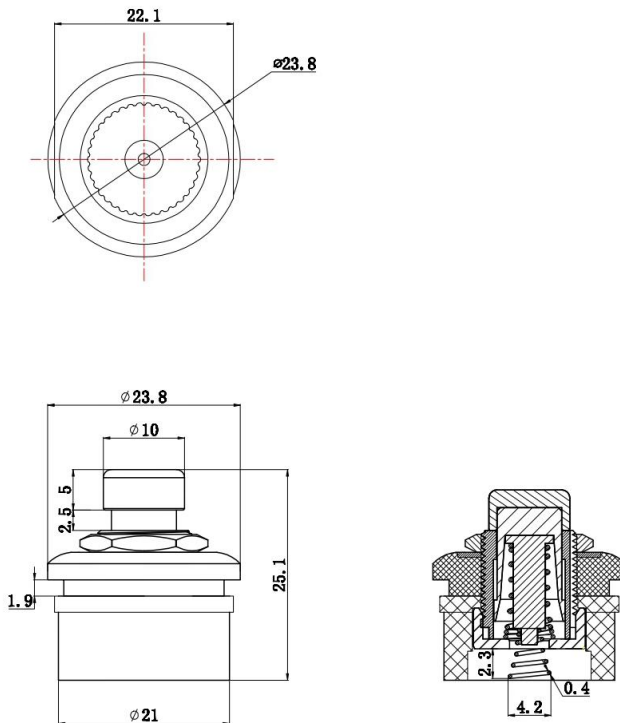



## YueQing Yulin Electronic Co., Ltd

Adds:F/6 No.19 Ke'aisi Road, Xiangyang industrial Zone,Liushi Town,YueQing City, Zhejiang Province, China 325600

Website: www.indicatorlight.com

Tel: 0577-62768130

Fax: 0577-62768130

### 3 配件材料 component material:

配件名 Accessory name	材料 material
button	Copper alloy
Sleeve	Zinc alloy
Stud	Copper alloy
Swing lever	Zinc alloy
Iron shell	stainless steel
Mid-foot side springboard	Copper alloy

### 4 温度范围 temperature range:

Working environment temperature: -25 °C ~ + 85 °C.

### 5 外观和手感 Appearance and feel:

#### 5.1 The signs are clear and firm;

Clean and beautiful appearance, no deformation, no damage, no cracking;

No rust, no poor plating;

The components are firmly connected without loosening or falling off;

#### 5.2 Switch operation is flexible, no jamming, no obvious friction.

### 6 电气性能 Electrical performance:

项目 Item	测试条件 Test conditions	技术要求 Technical requirements
---------	----------------------	-----------------------------



## YueQing Yulin Electronic Co., Ltd

Adds:F/6 No.19 Ke'aisi Road, Xiangyang industrial Zone,Liushi Town,YueQing City, Zhejiang Province, China 325600

Website: www.indicatorlight.com Tel: 0577-62768130 Fax: 0577-62768130

6.1	Switch Rating	250V2A/125V5A	
6.2	Insulation resistance	Apply DC500V between the copper feet and between the copper feet and the case, and measure after one minute.	$\geq 100M \Omega$
6.3	Pressure resistance	Apply AC2000V, 0.5mA, 10 seconds between the copper feet and the shell;	No breakdown or flashover.
6.4	Electrical durability	At rated load, it operates 30 times per minute for a total of 10,000 operations.	1. 1. Appearance and feel are qualified; 2. 2. Contact resistance $\leq 2 \Omega$ ; 3. Passed the withstand voltage test.

### 7 机械性能 Mechanical behavior:

7.1	Operating force	The switch is placed perpendicular to the operating direction, and the force is gradually applied to the side of the button to measure the maximum force required for the switch to conduct.	10-20N according to customer requirements.
7.2	Copper foot strength	Apply a 60N static load inward on the top of the copper feet for 60 seconds.	The terminals are not damaged and fall off, and the switch function works normally.

项目		测试条件	技术要求
7.3	Solderability	The copper feet were immersed in a molten tin bath at a temperature of $235 \pm 5^{\circ} C$ and a time of $3 \pm 0.5$ seconds.	More than 90% of the surface of the immersed part is covered with tin.

7.4	Resistance to welding heat	The soldered part of the copper leg was immersed in a molten tin furnace at a temperature of $260 \pm 5^{\circ}\text{C}$ for $3 \pm 1$ seconds.	<ol style="list-style-type: none"> <li>1. No significant deformation of the body;</li> <li>2. Qualified for mechanical and electrical performance tests.</li> </ol>
		手工烙铁焊接，焊接温度 $350 \pm 5^{\circ}\text{C}$ ，焊接时间 $3 \pm 1$ 秒。焊接时不得在铜脚上施加压力。	

## 8 耐候性能 Weatherability:

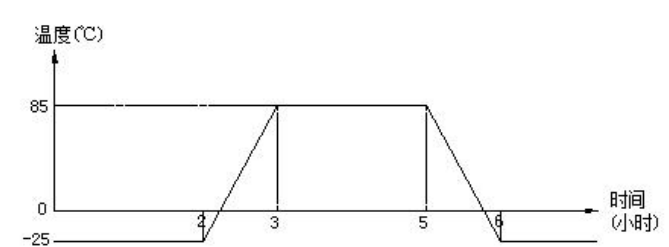
8.1	High temperature resistance	Leave it in the environment of $85 \pm 2^{\circ}\text{C}$ for 72 hours, and then leave it in the natural environment for 1 hour to test.	<ol style="list-style-type: none"> <li>1. Appearance and feel are qualified;</li> <li>2. Contact resistance <math>\leq 2\Omega</math>;</li> <li>3. Pass the withstand voltage test;</li> <li>4. Qualified mechanical properties.</li> </ol>
8.2	Humidity and heat resistance	It is left to stand for 96 hours under the environment of $40 \pm 2^{\circ}\text{C}$ and humidity of 91% -95% RH, and then it is tested after 1 hour in the natural environment.	
8.3	Low temperature resistance	Leave it in the environment of $-25 \pm 2^{\circ}\text{C}$ for 12 hours, and then leave it in the natural environment for 1 hour to test.	
8.4	Temperature change	<p>Perform the temperature change according to the temperature and time shown in the figure, for 5 consecutive cycles, and then leave it for 1 hour in the natural environment to test.</p>  <p>The graph shows temperature in degrees Celsius on the y-axis and time in hours on the x-axis. The temperature starts at 85°C, remains constant until 2 hours, then drops to -25°C at 3 hours, remains constant until 5 hours, and then returns to 85°C at 6 hours. This cycle repeats.</p>	